

F
A
L
L
2
0
0
9

Spurlock MUSEUM

THE ANNUAL PUBLICATION OF THE WILLIAM R. AND CLARICE V. SPURLOCK MUSEUM
AT THE UNIVERSITY OF ILLINOIS AT URBANA-CHAMPAIGN



This one-tenth scale replica of a Korean funeral bier is modeled on a late 18th-century original. Expensive, elaborately decorated biers were sometimes maintained as communal property. See page 10.



SPURLOCK MUSEUM STAFF

Wayne T. Pitard, Director
wpitard@illinois.edu

Dee Robbins, Assistant to the Director
darobbin@illinois.edu

Karen Flesher, Program Coordinator
kflesher@illinois.edu

Brian Cudiamat, Special Events Coordinator
cudiamat@illinois.edu

Christa Deacy-Quinn, Collections Manager
c-deacy@illinois.edu

John Holton, Assistant Collections Manager
jholton@illinois.edu

Melissa Sotelo, Collections Coordinator
msotelo@illinois.edu

Jennifer White, Registrar
jenwhite@illinois.edu

Amy Heggemeyer, Assistant Registrar for Acquisitions
heggemey@illinois.edu

Cheri Vitez, Assistant Registrar for Collections
cvitez@illinois.edu

Tandy Lacy, Director of Education
annlacy@illinois.edu

Kim Sheahan, Assistant Director of Education
ksheahan@illinois.edu

Beth Watkins, Education and Publications Coordinator
ewatkins@illinois.edu

Brook Taylor, Education Program Coordinator
taylorb@illinois.edu

Julia Robinson, Learning Center Coordinator
julorobi@illinois.edu

Jack Thomas, Director of Information Technology
jsthoma1@illinois.edu

Harold Bush, Head of Security
hcbush@illinois.edu

SPURLOCK MUSEUM MAGAZINE

PUBLISHER
University of Illinois Spurlock Museum, College of Liberal Arts
and Sciences

EDITOR
Beth Watkins

EDITORIAL COMMITTEE
Robin Fossum (chair), Dr. Ian Wang, Prof. Emeritus James
Sinclair, Dr. Allan Campbell, Wayne Pitard, Beth Watkins

CONTRIBUTING WRITERS
Dr. Allan Campbell
Prof. Emeritus Clark Cunningham
Robin Fossum
Bernie Freeman
Tandy Lacy
Dr. Tony Michalos
Dr. Barbara Oehlschlaeger-Garvey
Wayne Pitard
Prof. Emeritus James Sinclair
Kim Sheahan
Dr. Ian Wang
Beth Watkins
Dorothea Scott Whitten
Prof. Emeritus Norman E. Whitten

College of
**Liberal
Arts &
Sciences**

Produced for the Spurlock Museum by the College of Liberal Arts and Sciences
Office of Communications and Marketing.

Cover image: *Air Niugini / Kisim Pasindia igo / na ol femili oligo long konu na lukim Air Niugini (Air New Guinea transports passengers while a family looks on from their canoe).* John Siune, 2008. Textile, pigment.

Table of Contents

- 2 From the Director's Desk
- 3 Spurlock Board Update
- 4 Spurlock Museum Guild Report
- 4 Grants & Awards
- 5 **Causáunchimi! We Are Living!**
Dorothea Scott Whitten and Norman E. Whitten, Jr.
- 8 **The Creation of the Campbell Gallery Exhibit:
*The Transforming Arts of Papua New Guinea***
Ian Wang and Janet Keller with Kim Sheahan
- 10 **Spring Exhibit Preview: Korean Funerary Figures**
Beth Watkins
- 12 **The Merovingian Collection at the Spurlock Museum**
James Sinclair and Barbara Oehlschlaeger-Garvey
- 14 **A Conversation with Auditorim Benefactor
Betty Ann Knight**
Bernie Freeman
- 15 **Volunteer Extraordinaire: Martha Landis**
Robin Fossum
- 16 **An Introduction to the Spurlock Museum Gardens**
Allan C. Campbell
- 18 Calendar of Events
- 20 Friends of the Spurlock Museum



*Korean funerary figure:
Female attendant, late 19th century.*

Detail of shields and ancestor boards from Papua New Guinea. See page 8.



FROM THE DIRECTOR'S DESK

The Spurlock Museum has just concluded another successful academic year as I write this note. Our attendance rose some 13 percent this year over that of last year, and the temporary exhibit, *Children Just Like Me*, was a great success. Building on the enthusiasm registered by our young visitors, we plan to increase the number of child-friendly elements within the permanent galleries over the next year or so. Our Education Section, which already offers numerous programs for children from pre-K to high school, is at work on these new and exciting developments.

This issue of *Spurlock Museum* highlights the work of three of our tireless curators in the development of both temporary and permanent exhibits at the Museum. You will find an article here about the work involved in creating the Museum's upcoming exhibit on our remarkable collection of artifacts from Papua New Guinea, which opens September 1 in the Campbell Gallery. The exhibit is the result of countless hours of research and consultation by Janet Keller, professor of anthropology at the University of Illinois. She has shown extraordinary dedication and interest in helping the staff document and understand the items from this area in our collection, and she has been intimately involved in developing not only the exhibit but also several events that will be held in conjunction with it. Professor Keller wrote about some of her research on these pieces in "Bringing the Transforming Arts of Papua New Guinea to the Spurlock Museum" in last fall's issue of this magazine.

No less dedicated are Professor Norman Whitten and his wife and colleague Sibby, who have been working this year to create significant new elements in the South American side of the Laubin Gallery of Native American Cultures. The Whittens have provided the Museum with the core of its South American collection, and they have worked tirelessly to provide us with as much information and cultural context as possible about each artifact they have donated. During the past few years they have worked intensively with the staff to create new displays of material illustrating aspects of contemporary culture in Ecuador and Bolivia.

We cannot thank these three curators enough for their dedication to the Spurlock Museum. They reflect in the clearest manner the kind of love for this Museum that, I have found, is characteristic of our curators, volunteers, members of the Board and Guild, staff, donors, and friends. I am profoundly grateful for them and hope that you all will come to see their handiwork this fall.

While we are focusing on the current exhibits, we are also planning ahead for our exciting Centennial Celebration in 2011, which will include numerous events and a special exhibit commemorating the development of the Museum from its modest beginnings in Lincoln Hall to its transformation into today's institution with its own building. We invite you to participate in the celebration by checking the special section of our website at www.spurlock.illinois.edu/events/100. See how the Museum has developed over the last 100 years, contribute ideas for events, and share your own memories of favorite visits, events, and artifacts.

Wayne T. Pitard





Buckle and plaque. Frankish Gaul, 5th c. Bronze. 1924.02.0072.

BOARD UPDATE

Dear Board members, colleagues, and friends of the Spurlock Museum:

As the incoming president of the Board of the Spurlock Museum, it is an honor and pleasure for me to provide you with my first update on the Board's activities. On April 7, 2009, the Board held its spring meeting at noon in the Champaign Country Club. It was attended by 17 Board members, the director, and Museum Liaison Brian Cudiamat. A business meeting was followed by a buffet

lunch and then an extended discussion of suggestions by Board members and trustees on ways to improve the functioning of the Board, including streamlining

some activities and expanding others. We thank Trustee Charles Hundley for arranging the meeting at the Country Club. In the spring newsletter I will be able to report on more specific outcomes of the spring meeting.

A rethinking of the Board's activities at this time is appropriate given the recent appointment of the new Museum Director Wayne Pitard; the feedback from the review for accreditation by the American Association of Museums and its two site visitors who came April 13 and 14; and our upcoming fundraising effort and celebration in 2011 of the centennial of cultural museums



Members of the Spurlock Board with our AAM accreditation site visitors from university museums in Texas and Alaska.

on the University of Illinois campus. At the conference of the Central States Anthropology Society (April 2–5, 2009), hosted this year by the Urbana-Champaign campus, Pitard gave a delightful lecture about his ongoing research on the history of museums at the University of Illinois, which he will present for the Board and readers of the magazine in the future. Pitard and several curators then hosted a tour of the galleries for conference participants.

I wish to extend heartfelt thanks to Dr. Ian Wang, my predecessor as president of the Board, for his many and stellar contributions to the Board. He and Robin Fossum, chair of the publications committee, deserve special plaudits for the continuing development of this publication. Thanks also to Dr. Allan Campbell, incoming vice president of the Board, for his many efforts on behalf of the Board and the Museum.

Finally I want to encourage Board members and other friends of the Museum to volunteer for some of the diverse activities of the Museum. Your help will be most appreciated.

Sincerely,

Clark E. Cunningham
President of the Board
Emeritus Professor of Anthropology

MUSEUM BOARD

Anthony Ackerman, *Board Member*
Rosalinda Barrera, *Board Member*
Harlan Berk, *Board Member*
Henry Blackwell, *Board Member*
Allan Campbell, *Trustee*
Mehri Cowan, *Board Member*
Clark Cunningham, *Board President*
Brian Cudiamat, *Museum Liaison*
Robin Douglas, *Board Member*
Emmie Fisher, *Board Member*
Mary Forsyth, *Board Member*
Robin Fossum, *Trustee*
Gregory Freund, *Board Member*
Terry Hamrick, *Board Member*
John Heiligenstein, *Trustee*
Charles Hundley, *Trustee*
Jill Knappenberger, *Board Member*
Sara Lo, *Trustee*
Anna Merritt, *Board Member*
Tony Michalos, *Guild President*
Richard Pyatt, *Trustee*
Adlon Rector, *Board Member*
Elizabeth Rogers, *Board Member*
Charles Shepardson, *Board Member*
James Sinclair, *Trustee*
Edith Stotler, *Board Member*
Joy Thornton-Walter, *Board Member*
Curt Tucker, *Board Member*
Ian Wang, *Trustee*
Wayne Weber, *Board Member*
Dorothea Whitten, *Board Member*
Norman Whitten, *Board Member*
Joyce Wright, *Trustee*
Grover Seitzinger, *Honorary Board Member*



SPURLOCK MUSEUM GUILD REPORT

Dear Friends of the Spurlock:

It is my distinct pleasure to start my tenure as president of the Spurlock Museum Guild. My wife Joannie Stathos and I have been active with the Guild the past several years and we have enjoyed supporting such a jewel of a Museum at the University of Illinois. Coming from a Greek heritage and tradition, I am particularly proud and honored to step into this role. The Spurlock Museum represents the wealth of world culture in both displays and words. A visit at the Museum is often the first introduction of the world's heritage to children and their school groups.

The Spurlock Museum Guild was formed in 1989, and this year we proudly celebrate our 20th anniversary. The Guild is committed to education by sponsoring literary and cultural events for schoolchildren and adults through the Museum. Our annual fundraisers and auctions give us the resources to realize important educational objectives. Over these 20 years, the Guild has donated over \$350,000 to the Museum.

The Museum's gardens are meticulously maintained by volunteer master gardeners who are members of the Guild. The gardens are not only ornamental, full of beautiful flowers, herbs, and medicinal plants, but they are teaching gardens as well. Members of the Guild also volunteer for various duties in other sections of the Museum like Registration and Education.

The Guild accomplished many goals in 2008-2009. Following our Children of the World Auction last fall that raised over \$30,000, we hosted a holiday party at the Museum, a winter luncheon at the Champaign Country Club with Museum representative and new staff member Cheri Vitez addressing Guild members, and our annual dean's luncheon at the University of Illinois Foundation hosted by the new dean of Liberal Arts and Sciences, Professor Ruth Watkins.

We celebrate the 20th anniversary of the Guild at our next auction on Friday, October 30, 2009, at the I-Hotel in Champaign. The theme will be "Guided" in Platinum.

The Nominating Committee slate of 2009-2010 officers was approved at the May meeting. The new officers of the Guild are: Tony Michalos, President; Kathy Kinser, President-Elect; Robert Fossum, Treasurer; Beth Felts, Recording Secretary; Judy Hummel, Corresponding Secretary; Robin Fossum and Claire Skaperdas, Past Presidents. I welcome new Executive Committee and Guild members and I am looking forward to working with them.

The Guild always welcomes new members and volunteers. To join, please send a message to Treasurer Robert Fossum at robertfossum@gmail.com.

Tony Michalos

GRANTS AND AWARDS

- Tandy Lacy, Director of Education, received a grant of \$10,100 from the Ethnic and Folk Arts Program of the Illinois Arts Council in support of performance events and special programs featuring guest artists from around the world.
- In collaboration with nine other state museums and libraries, the Spurlock Museum was awarded \$40,000 from the Institute of Museum and Library Services Connecting to Collections Grant for the project "Development of the Illinois Collections Preservation Plan and Network."
- The Center for East Asian and Pacific Studies has been awarded \$4,000 in Title VI grant funds for an exhibit project for undergraduate students at the Museum. Undergraduates in history and anthropology were hired specifically for this project and will research and develop an exhibit and related educational materials on East Asian wood carvings from the Fred A. Freund Collection. Their special exhibit will open in Fall 2011.



As this publication goes to press, word has arrived that the Spurlock Museum has been accredited by the American Association of Museums, a multi-year application and review process that has finally culminated in this great honor. More details to come in our winter newsletter.



Inlaid buckle. Frankish Gaul, 5th–8th c. Bronze, stones. 1924.02.0068.

German Flores, master mask maker, in his workshop, Oruro, Bolivia. Courtesy of Cynthia LeCount Samaké.



Causáunchimi! WE ARE LIVING!

UPDATE OF THE SOUTH AMERICAN EXHIBITION OF THE AMERICAS GALLERY

By Dorothea Scott Whitten and Norman E. Whitten, Jr.

The title of the Americas Gallery, *Causáunchimi! We Are Living!*, was chosen to reflect the cultural orientations and historical roots of contemporary indigenous peoples in North and South America. The Ecuadorian Quichua word *Causáunchimi* stresses the present as a reflection of a dynamic past.

Four core themes guide the South American exhibition: Control of Power, Presentation of Self, Sounds of Spirits, and Sustaining Life. Additional artifacts, illustrations, maps, and informational texts supplement these displays.

Working with Spurlock staff members Christa Deacy-Quinn, Amy Heggemeyer, John Holton, Melissa Sotelo, and Beth Watkins, we are now concluding a five-year review and revision of the South American displays. We describe here significant changes including new acquisitions. Two cases, Sustaining Life and Sounds of Spirits, together with new supplemental displays, have undergone major revisions. The two others, Control of Power and Presentation of Self,

received cosmetic updates, while a large ceramic display needed only minor adjustments.

Sustaining Life

The finest contemporary ceramics in Amazonian South America are made by the Canelos Quichua women of Ecuador and the Shipibo-Conibo women of Peru. Ceramics (pottery) in these regions date to approximately 4,500 years ago (2,500 BCE) and are well represented in Spurlock holdings, with many pieces featured in this gallery. Canelos Quichua women continue to make two forms of pottery: smoke-blackened ware to cook and serve various foods, beverages, and spices; and polychrome, decorated ware to store and serve a slightly fermented food-beverage, called *asua*, which is the staple of life.

Like their Shipibo-Conibo counterparts, Canelos Quichua women grow the manioc (cassava, *yuca*, *Manihot esculenta* Crantz) from which they make large quantities of manioc food-beverage, and

they also control the production of pottery. Both garden soil and pottery clay are the domains of the mythical feminine spirit Nungüi. An effigy figurine depicting her transformation into Jilucu, the Potoo bird, is included in the revised Sustaining Life case. Also included is an effigy of Cachi Amu, overseer of salt mines, and examples of black ware associated with salt.

Pottery in Canelos Quichua and Shipibo-Conibo cultures is the exclusive domain of women. A



Sustaining Life display with Hilucu (left) and Nungüi (right).

"It is thought that music most clearly conjoins human and spirit worlds."

potter rolls clay coils on a carved wooden board, builds up the walls, scrapes the pot with pre-formed calabash shells, burnishes it with water-polished stones, and then decorates it with clay and stone paints, using a bit of her hair affixed to a small stick as a brush. Firing, without a kiln, is at about 1,400 degrees Fahrenheit. A display of the hand-coiled pottery manufacture, from clay coil to green ware, includes an image of the face of Nungüi on a small storage jar for special stones and feathers.

A nearby case contains materials used in the production of food from manioc in different areas and cultures of South America. These include a large wooden mortar for pounding peeled and cooked manioc roots, a wood pestle, and baskets for extracting bitter juices from the pulp and for sifting and serving the toasted manioc (*farinha*). Extracted manioc juice is the basis of our well-known tapioca (itself a word from the indigenous Tupi-Guaraní language). Also included are ceramic pots for cooking, storing, and serving manioc. Another figure of Nungüi oversees this display.

Sounds of Spirits

Music and rhythm are integral to public performances such as festivals and rituals. It is thought that music most clearly conjoins human and spirit worlds. This case has been redesigned to highlight musical instruments and festival activity of the Canelos Quichua indigenous people of Amazonian Ecuador while two additional cases display the musical-festival complexes of Afro-Ecuadorians, indigenous Andean Salasacans, and Andean Bolivians.

A major addition to Sounds of Spirits is the ceramic representation of festival performers. A set of six small figurines includes three females and three men with feather headdresses, cornets, and drums.

One wears a large bandolier-like festival adornment. The women and some men hold drinking bowls and the leaders of the festival sit on special stools and benches. This lively group was made by Marta Vargas Dagua to convey her cultural heritage to



Marta Vargas and her pottery festival performers in Puyo, Ecuador, 2007.



Sounds of Spirit display with Marta Vargas' festival performers in foreground.

Spurlock viewers. Marta, a daughter of Estela Dagua, master potter who made the Cachi Amu effigy jar, grew up in an urban setting and learned much of her cultural knowledge about festivals from visitors from outlying rain-forest territories.

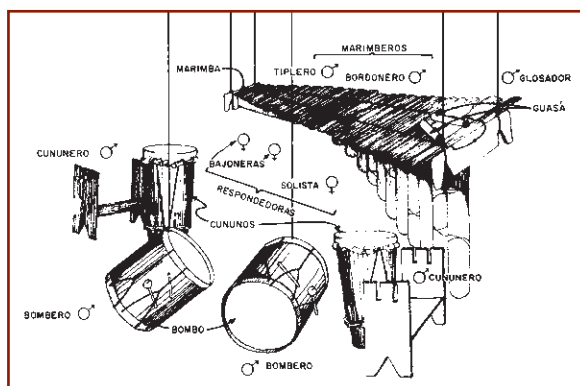

Artist's rendition of marimba instruments.

People of African and African-Spanish descent in the coastal rain forest of Ecuador and Colombia continue to recreate the most African musical complex in the Americas. The marimba dance and rhythm instruments

have attracted worldwide attention over the past two decades. The marimba (xylophone) and instruments are displayed in two supplemental cases. The popularity of Afro-Ecuadorian marimba music and dance has led to the creation of several marimba schools to assure continuity in younger generations.

Self-liberated people of African descent emerged in northwest Ecuador in the mid 1500s, and by 1599 they had secured their territory known as the "Emerald Forest." There they established a rich cultural system with the marimba ensemble as central. Although the marimba music and songs attract a dangerous female spirit, La Tunda, whom the Spanish called a "devil," she is chased away by the bass drum and cannot enter the realm of performers.

Devil Imagery in South America

Next to the marimba complex is the display of one of Spurlock's recent acquisitions, the stunning costume and mask of a Bolivian Diablada (devil) dancer. This is one of many costumed dances performed during the time of Carnival (or Carnaval) by indigenous and other Andean Bolivians. Origins of the performances date to medieval southern Europe.

Following the Spanish conquest, indigenous and

African-descended people were enslaved and forced to work in Bolivian silver mines. Both had rich cosmologies that included many spirits. The spirit of the underworld, which became the master spirit of the mines, was called Supai, regarded by the colonial rulers, clergy, and overseers as a “devil.” Workers in the mines came to call him Tío, “uncle” in Spanish, and to leave offerings to him for their own protection.

During a period of native rebellion in the 1780s indigenous people dancing as costumed “devils” from the mines first appeared, and later they came to lead revelers during the pre-Lenten Festival of Carnival. In 1904 an organization called the “Gran Tradicional Diablada Oruro” was formed and from 1914 to the present the troupe of masked devil dancers has led the opening of Carnival in Oruro, and later in such cities as La Paz, El Alto, Cochabamba, and Santa Cruz.

Another dance troupe in these Carnival performances is that of the Morenada, which symbolizes the power of black workers (*morenos*) also ascending from deep in the mines to create reversals and disruptions in the colonial world. Each costumed black dancer carries a noisemaker called a *matraca*. It is said that the grating sound of this instrument reflects the sounds of the chains of enslaved African-descended people. In 2009 the Spurlock Museum obtained from Cynthia LeCount Samaké, four *matracas*, two of which are to be displayed.

The devil costume was made for Spurlock in 2007 by an Oruro costume maker living in Cochabamba and acquired for the museum by Isabel Scarborough, a PhD candidate in anthropology at the University of Illinois. It is adorned with dragons and serpents, which may be interchange-

able and symbolize either good or evil in European and Asian representations. The mask was made in 2009 specifically for the Spurlock Museum by master craftsman German Flores in Oruro and acquired through the auspices of Cynthia LeCount Samaké, author of the chapter entitled “Bolivia” for the book *¡Carnaval!* The face of the mask is that of the European horned Devil. On its head is a three-headed dragon, with a small snake and a small dragon. The Aymara- and Quechua-speaking people of this region of Bolivia say that the ultimate power of the universe sometimes comes to the Andes as a mighty anaconda snake from the Amazonian region.

Quechua speakers call the anaconda *amaru* (*amarun* in Canelos Quichua); in Aymara it is known as *katari*. When this serpent comes to the Andes, as when devils emerge from the mines, the world is disrupted and all sorts of reversals and inversions take place. Enactment of such disruptions, reversals, and inversions, as symbolized by the Devil mask with dragons and snakes on its head, is the essence of the origins of this particular entry to Carnival in the colonial period and continues today in highly choreographed and increasingly elaborate and innovative performances.



Our five-year review involved not only the upgrades of the South American section of the gallery but also serious study of contemporary indigenous cultures

upon which the gallery themes are built. The vibrancy of the new acquisitions described here illustrate that South American peoples and cultures are indeed “living” and expanding their systems of imagery and performance in today’s dynamic world.

Dorothea Scott Whitten is research associate of the Center for Latin American and Caribbean Studies and adjunct curator of the Spurlock Museum.

Norman E. Whitten, Jr. is professor emeritus of anthropology and curator emeritus of the Spurlock Museum.

Diablada dancer in performance, Oruro, Bolivia. Courtesy of Cynthia LeCount Samaké.

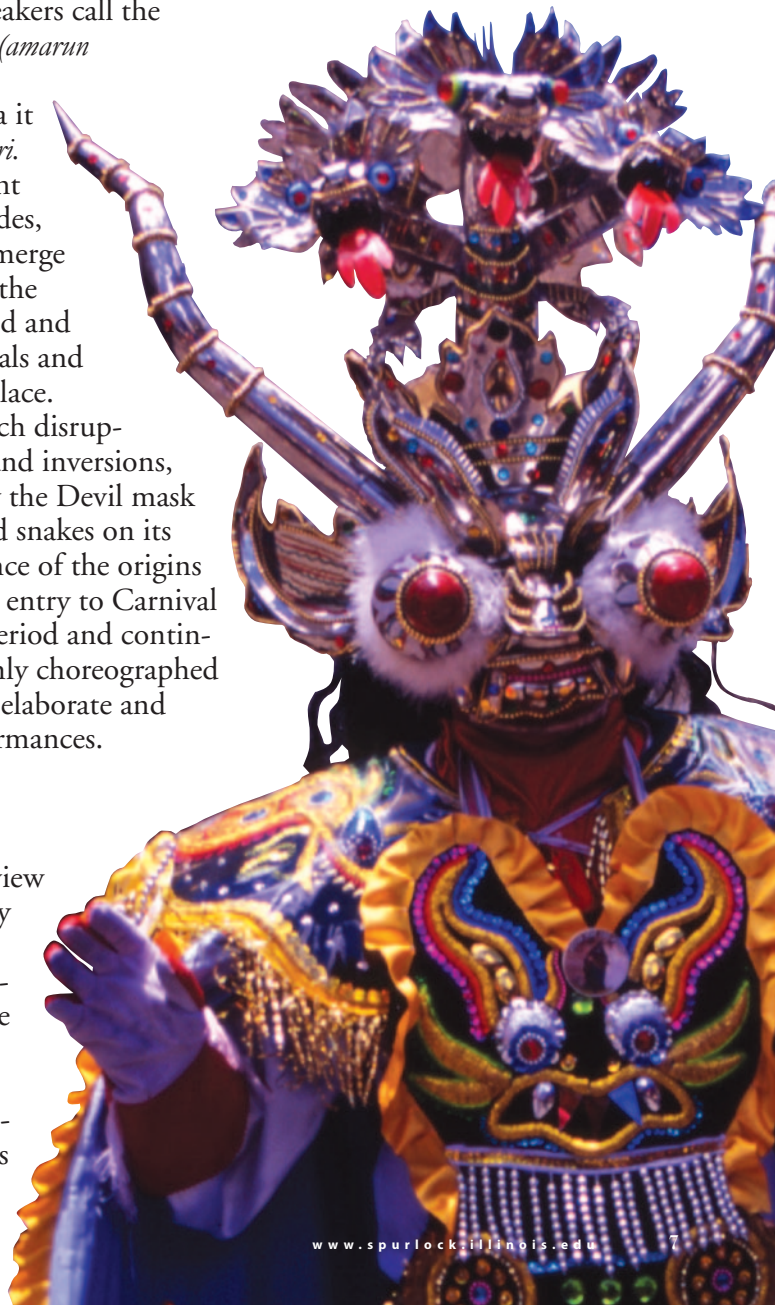

AN INSIDE LOOK: THE CREATION OF THE CAMPBELL GALLERY EXHIBIT

THE TRANSFORMING ARTS OF PAPUA NEW GUINEA

by Ian Wang and Janet Keller
with Kim Sheahan



Professor Janet Keller examines some shields and ancestor boards.

last spring's *Children Just Like Me*. Lacy led two lobby exhibits in the 2007–8 academic year, *Qak'aslem, Qakem: Kaqchikel Maya Weavings* and *Uncovering Life's Third Domain: The Discovery of Archaea*, and the fall 2006 Campbell Gallery exhibit *Where Animals Dance*. Sheahan has worked most recently as the coordinator for the staff-developed Campbell Gallery exhibits *Following the Paper Trail from China to the World* and *Why Knot?*, and she is also working on an upcoming lobby exhibit featuring artifacts

When Spurlock Museum guests visit, they view exhibits that have taken years to create and complete. They have little opportunity to gain insight into the planning and preparations that go on behind the scenes. Although I have been an exhibit curator for many years, I still find the process of creating *The Transforming Arts of Papua New Guinea* exhibit fascinating and somewhat incredible. To give readers an inside look at the multi-year process and the effort involved in creating the exhibition, I interviewed the exhibition curator Janet Keller, professor of anthropology at U of I, and exhibit coordinator Kim Sheahan, the Museum's Assistant Director of Education. They worked with Museum staff and an array of artists and citizens of the country of Papua New Guinea in putting together this original display for the Campbell Gallery of the Spurlock Museum.

Preparations began with research. Two undergraduate interns, Alexa Wirth and Rebecca Chan, worked with Professor Keller in 2007–08 to research the Tobin collection, the basis for the exhibition. This collection was acquired in 2004 from the Logan Museum of Anthropology at Beloit College. With the guidance of Christa Deacy-Quinn and John Holton, over 300 artifacts were reviewed. The interns then carried out background research and recommended about 40 artifacts for the exhibit. Keller flew to Papua New Guinea during a sabbatical to meet local artists and to discuss the exhibit with them. On return from the South Pacific, Keller joined forces with Spurlock Museum staff members to collaborate further on the exhibition development process.

Professor Keller worked most closely in this process with Sheahan. As exhibit coordinator, Sheahan makes sure that all the facets of the exhibit development process continue to move forward within the assigned timeline, which is coordinator-created with input from all the Museum sections and the curator. Education staff Sheahan, Tandy Lacy, and Beth Watkins all serve as coordinators of temporary exhibits on a rotating basis. Watkins served most recently as the coordinator for *Ancient Egypt: The Origins*, curated by previous Museum Director Douglas Brewer, and two traveling exhibits, *Calypso Music in Postwar America: Photographs and Illustrations, 1945-1960* and



Keller and Collections Manager Christa Deacy-Quinn look at details on the back of an artifact.

donated by Fred Freund.

Most of the Museum's senior staff members were involved in *The Transforming Arts of Papua New Guinea*. Here are highlights demonstrating how exhibit creation is truly a team effort.

- The Collections management team, headed by Christa Deacy-Quinn, John Holton, and Melissa Sotelo, facilitated and supervised all contact with the artifacts for research and photography. As mentioned by Janet Keller, "Each visit to the artifacts transformed our knowledge of the integration of the material culture and the story line, hopefully improving the information we have provided." Deacy-Quinn created the design of each exhibit section and suggested the exhibit colors. Choosing colors may sound easy, but it's a complicated process. The Collections staff members try out various combinations of colors and artifacts, consulting with Education staff on how the colors work with label and graphic



design and legibility and with the curator about the cultural significance of various colors. The effects of different colors can be amazing and unanticipated; particular combinations bring out the objects on display, highlighting the artifacts' colors, textures, and shapes. The wall and mount colors must function as an unobtrusive background, yet when well chosen they animate everything visitors will see. The team, in concert with their U of I student employees, planned, constructed, and installed all needed mount furniture, as well as special pedestals, platforms, reader rails, and interactive pieces.

- The Registration section, under Jennifer White, Amy Heggemeyer, and Cheri Vitez, entered Keller's detailed research notes into the artifact database and handled the shipping details for the loan of one artifact and several images from the collection's original home at the Logan Museum of Anthropology. Registration also kept track of all the Spurlock Museum artifacts designated for the exhibit, as well as any movement of artifacts around the Museum for research and design purposes. Student staff members in this section photograph all the artifacts as needed for label captions, detail images, large-scale graphics, and publications.

- Most of the Museum's temporary exhibits now involve the addition of a computer kiosk area, where visitors can enjoy multimedia explorations of the exhibit topic. Sheahan and Keller worked with Jack Thomas, Director of Information Technology, to create the kiosk offerings. The IT section also stores and cares for the recordings of exhibit-related presentations, which may be made available to area educators.

- Education staff members Sheahan, Lacy, and Watkins were deeply involved in the exhibit creation process. They worked with the curator in the writing, editing, and designing of the exhibit labels. Keller says, "The editing was a crucial step, as the final text tells the story we wanted to offer the many segments of the community: children, adults, scholars, lay public, students, professors, artists, and appreciators of the arts. Reaching out to so many public spheres is a tremendous challenge that the educators facilitate for us all." Watkins designed the colorful sidebars that accent each label and tracked all information (e.g., size, owner, identification, copyright permissions) on each of the images considered for the exhibition using a unique Spurlock-designed database. She also created the special map Keller requested for the exhibition.

- Keeping track of the construction material purchases, copyright fees, speaker contract payments, loan fees, and the myriad other payments that are part of an exhibition is handled by the Administration section. The Business office staff of Dee Robbins and Karen Flesher ensured that all

necessary University paperwork was completed accurately and punctually.

Campbell Gallery exhibitions also serve as the basis for unique educational experiences, and planning for these was incorporated into the exhibition's development timeline. Two exhibit-specific school tours will be offered for the duration of the display. Imaginative in-house games, crafts, and activities are offered that promote learning and engagement with the materials and themes. Often, an event referred to in-house as an "extravaganza" will also be planned. During extravaganzas, 200 schoolchildren will come to the Museum for an event that combines a professional performance in the Knight Auditorium with time in the temporary exhibit and related exhibits within the building. As the curator, Professor Keller will give a short talk on the exhibition as part of the opening reception on September 25.

Keller also recommended performers familiar with the culture on display and scholarly experts who can offer lectures on the topics explored in the exhibit. The hope is to create interest in the exhibit in various area communities, from the public schools and students of the arts and anthropology, to other museums and scholars interested in international and global studies. The Museum's goal is to generate as much dialogue about the exhibit as possible and advance our own



Registration staff Carol Kussmann and Jennifer White take a closer look.

and our community's knowledge of the world in the process. For this exhibit, the Museum is very pleased to announce a multi-day visit by Dr. Michael Mel, a world-renowned performing artist from Papua New Guinea. Among other events, Dr. Mel will present

this year's Campbell Family Lecture, talk with medical school students, and meet with Keller's class while he is here. The Spurlock Museum Guild Performance and Lecture Series will feature as lecturer Dr. Jacquelyn Lewis-Harris, the director of the Center for Human Origins and Cultural Diversity at the University of Missouri–St. Louis.

Keller summarizes the relationships between developing the exhibit and its related programming: "When we wrote thematic text for one section it influenced what we wanted to say in another; as we thought about performers and speakers, we were required to rethink what the exhibit should provide as background. As we anticipated visitors of diverse communities, we considered what they would most want to know about the artifacts we have the privilege of sharing with them. *The Transforming Arts of Papua New Guinea* has been an orchestration of an amazing diversity of creative skills made possible only by the incredible contributions of the Spurlock Museum staff! For all of us involved, it was such an amazing process; it was always in transformation."



SPRING EXHIBIT

Korean Funerary Figures: Companions to the Journey to the Other World by Beth Watkins

Cultures around the world and throughout history have complex responses to the very human occupations of death, mourning, and wondering about what lies beyond.

When exploring the Museum's nine feature galleries, visitors can see dozens of artifacts that tell us how their makers viewed the end of life, whether with sadness, hope, or even the confidence of a well-stocked tomb full of everything needed for the afterlife. In 2004, the Museum featured a temporary exhibit on one well-known example of such responses: the festivities surrounding the remembrance of the dead during the Day of the Dead holiday in different parts of Mexico. *Celebration of Souls* combined photographs of celebrations and commemorations in Oaxaca with folk art depicting lively, cheeky skeletons indulging in favorite activities from the realm of the living. The 2005 exhibit *Following the Paper Trail* featured

Chinese funerary items that are burned and sent to cherished ancestors as smoke.

The Museum will explore attitudes towards death again this spring with another traveling exhibit, *Korean Funerary Figures: Companions to the Journey to the Other World*, organized by the Korea Society of New York and the Ock Rang Cultural Foundation in Seoul. *Korean Funerary Figures* features more than 70 *kkoktu*, engaging, sometimes whimsical funerary carvings from late 19th- and early 20th-century Korea. It may come as a surprise to those who expect funerary art to be solemn and teary that these colorful wooden figures decorated the biers used to carry coffins to traditional mountainous burial grounds. *Kkoktu*

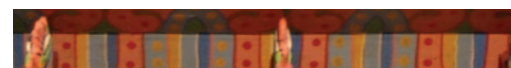



PREVIEW

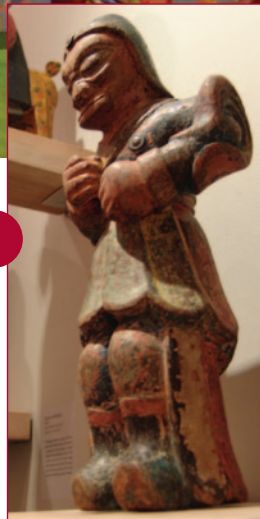

- A.** This one-tenth scale replica of a funeral bier is modeled on a late 18th century original. Expensive, elaborately decorated biers were sometimes maintained as communal property.
- B.** Korean funerary figure: Warrior, late 19th century.

express a community's hope that the deceased will enter the next world enveloped by comfort and joy. They also provide valuable archaeological evidence of village life from a period with sparse written records. The exhibit is filled with humanoid, animal, and mythical figures, as well as a replica of a funeral bier. The humanoid figures, who serve as connections between this world and the spiritual realm, fall into four basic categories: guides lead the deceased on the right path; guards frighten off evil spirits; caregivers help provide the comforts of this world; and entertainers balance the mourning and instability of the time of death with music, dance, drama, and laughter. Dragons protect the deceased, while various birds, par-

ticularly the phoenix, represent the transcendent flight into the next world.

Korean Funerary Figures is the first exhibit outside Korea to feature kkoktu, and the Spurlock Museum is the exhibit's only venue in the Midwest as it tours the United States before a showing in London in 2011. The exhibit opens March 2, 2010, and runs through July 11. Check our website calendar for related special events and educational opportunities.

All of the objects in this exhibit are on loan from the permanent collection of the Seoul-based Ock Rang Cultural Foundation. Support for this exhibit was provided by the Korea Foundation.

The Merovingian Collection at the Spurlock Museum

By James Sinclair and Barbara Oehlschlaeger-Garvey

Over the years, the Spurlock Museum has been the fortunate inheritor of vast and comprehensive collections. The philosophy of the early curators of the Museum of European Culture (one of Spurlock's many precursors) was to purchase "study collections." Their concern was not exhibition but research, and they strove to provide students with rich, deep, and varied groups of objects from which to learn. The Merovingian Collection, bought by Professor E.C. Hayes in 1924 while on sabbatical in France, is one of the most impressive of these, although its importance has only recently been understood.

Who were the Merovingians? After the fall of the Roman empire, in an era generally known as the Dark Ages, much of Northern France was occupied by Franks (from whom France gets its name), a people who had migrated from the area that is now Germany. The Franks collaborated with, served with, and eventually replaced the Roman legions in Gaul. Their legendary first



"Whorl" fibula. 5th-8th c. Bronze.
1924.02.0055.

king, Merovech, gave his name to a dynasty that would last until 751 CE.

The Spurlock's collection consists of over 250 artifacts. Frankish swords and axes, knives and scissors, jugs and cups, fibulae and earrings and beads,

and every manner of belt buckle are included. Few North American museums hold more than a handful of such early medieval pieces.

There are strong collections in the Metropolitan Museum in New York and the Royal Ontario Museum in Toronto, but the Spurlock's collection rivals these in number. A small selection of these pieces is on permanent display in the Museum's Gallery of European Cultures.

Referred to for many years as the Baudon collection, these pieces were believed to have belonged to Theodore Baudon, a world-renowned French archaeologist of the early 20th century. Yet none of the published catalogues of his material included Spurlock's pieces. About 40 of the objects were accompanied by small paper labels with a plate and figure number, a short description, and a rudimentary drawing of the piece. In her dissertation research, Barbara Oehlschlaeger-Garvey discovered that the Spurlock objects were not Baudon's but instead came from an early excavation of graves by

Background: Bead. Mid-5th-7th c. Amber. 1924.02.0539.

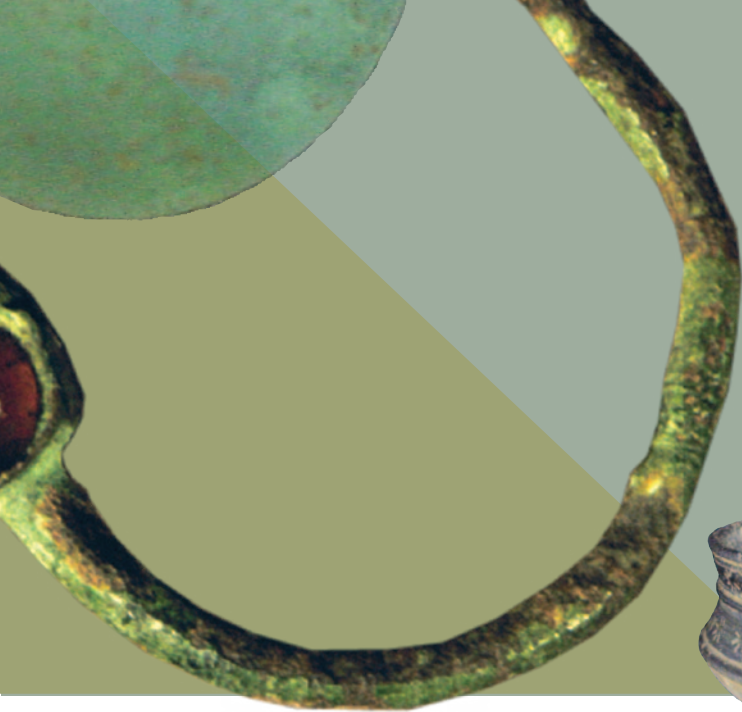

Earring. 5th-8th c. Bronze, gem. 1924.02.0047A.

Auguste Moutié, done in the 1830s on a small hilltop near Houdan, France, called La Butte des Gargans. Moutié, a young medical doctor, engaged an artist, his friend Paul Guégan, to illustrate his manuscript of his findings with precise sketches and drawings describing the graves and their assemblages. Guégan's beautiful watercolor album and Moutié's excavation narrative are now housed in the Musée D'Archéologie Nationale outside Paris. The Spurlock labels (and their accompanying pieces) match these manuscripts in every detail: they must have been Guégan's working notes. Oehlschlaeger-Garvey matched over 100 of the pieces in the Spurlock collection to Moutié's excavation notes, Guégan's drawings, or both. The provenance of Spurlock's Merovingian objects is now assured.

Why is this important? Auguste Moutié was far ahead of his time. Unlike his contemporaries, his digging and recording methodologies were relatively precise. Archeology itself in the 1830s was a new field. Outside of Pompeii, it can hardly be said to have existed. Moutié described the location, each grave, and the proximity of one grave to another. Moutié was so precise that whole grave assemblages can be re-created, and the Spurlock pieces can be understood in context. While the Franks has assimilated themselves into Roman culture, below ground they retained the burial customs of their barbarian past. The people buried on this hilltop were interred with their distinctive weapons, with their elaborately carved and bejeweled belt buckles. It is our good fortune that the Merovingian collection was pur-



Colored beads. 5th-6th c. Glass, ceramic. 1924.02.0129.



Carinated bowl. 6th c. Ceramic. 1924.02.0351.

chased as it was for study. However, in light of this new evidence, the whole notion of a "study collection" has changed. The Spurlock Merovingian collection is no longer a list of good examples of certain object types. It now represents a precise site, an early and excellent example of the burial customs of Frankish culture in the fourth to seventh centuries, and the work of an archaeology pioneer.



Buckle and plaque. 5th c. Bronze. 1924.02.0072.

References

Effros, Bonnie. "Art of the 'Dark Ages': Showing Merovingian artifacts in North American public and private collections." *Journal of the History of Collections* 17, no. 1 (2005): 85-113.

Oehlschlaeger-Garvey, Barbara. "Reconstructing the Merovingian Cemetery of Butte des Gargans, Houdan France: the documents of Auguste Moutié and Paul Guégan considered with the collections of the Spurlock Museum of World Cultures and the Musée d'Art et d'Histoire de Dreux." PhD diss., University of Illinois at Urbana-Champaign, 2000. 264 pages.



A CONVERSATION WITH AUDITORIUM BENEFACTOR **BETTY ANN KNIGHT**

by *Bernie Freeman*

Dressed in blue pants and orange socks, there is no mistaking that the University of Illinois at Urbana-Champaign is very important to Betty Ann Knight. “The University gave me everything,” she says with pride. And Betty Ann has given back generously...for scholarships and fellowships in electrical engineering, to athletics, to Japan House, and to the Spurlock Museum.

She recalled a summer when she was about 10 years old and the family drove from Urbana to Schenectady, N.Y. She and her brother and their mother and father rode in the family’s Willys-Knight automobile and camped along the way. “Mother always slept in the car, though she didn’t like being without conveniences!” said Betty Ann. Perhaps those early family vacations were the foundation for Betty Ann’s love of travel and, in turn, her love of travel may have been responsible for her becoming so involved with the former World Heritage Museum and later the Spurlock Museum. She has been a strong advocate for this Museum for many years.

“When I first volunteered, I went to the World Heritage Mu-

seum on the fourth floor of Lincoln Hall on Saturdays and gave tours or manned the desk.... I did whatever they needed.” She recalled a rather conservative-minded group that came for a tour one day. “They took one look at the nude statues and off they went!”

Education is in Betty Ann’s genes. Her paternal grandfather was an industrial arts professor at Ohio State University (OSU), her father was an undergrad at OSU, and her mother graduated from Antioch College in Ohio. It was a teaching opportunity that took her parents from Ohio to Illinois. “I was actually born in a home in Champaign because there was some kind of disease going around the hospital so Mother couldn’t go there.”

Betty Ann’s father, Abner “Buck” Knight—for whom the Knight Auditorium in the Spurlock Museum is named—earned his MS and PhD degrees while at the University of Illinois and was a member of the electrical engineering faculty for 41 years. He knew the value of a good education; thus, there was no question that Betty Ann and her brother would attend the University of Illinois. William Knight received

a degree in electrical engineering and Betty Ann earned three degrees: a BS in home economics, an AB in human resources, and a Masters in social work. She spent her entire career in education either teaching or as a school social worker.

It’s easy to see why learning and sharing knowledge with others comes naturally for Betty Ann and why she is so passionate about the University of Illinois and especially about what the Spurlock Museum offers. When the Spurlock Museum was being designed, Betty Ann said, “I looked at the plans and there wasn’t an auditorium!” Betty Ann fondly remembered her father performing in many faculty plays at the U of I. Because of her love for her father and the Museum, she decided to make a gift that would make possible the A.R. (Buck) Knight Auditorium and provide the Museum with a theatre for lectures and seminars, as well as a place for performances by actors, storytellers, choral and instrumental groups, and others. “I think it’s important to have such a fine museum—and when you do, you’re happy to use your time (and resources) to support it.”

The Knight Auditorium is a lovely space enjoyed by many. Thank you, Betty Ann!

When inquiring at the Museum about finding the ultimate volunteer, the name Martha Landis was at the top of every staff member's list. Martha has many ties to the University of Illinois, but the Spurlock Museum has been one of her favorite subjects.

Martha's father, Paul Landis, came to Illinois to study for his doctorate in English. After completing his degree in 1923, he married Agnes

by Director Douglas Brewer and Board member Dr. Grover Seitzinger to serve as the secretary of the Board at the new Spurlock Museum. Staff member Kim Sheahan also soon recognized Martha's considerable talents and invited her to volunteer in the "back rooms" of the Museum. Following her retirement from the library as an associate professor 13 years ago, Martha soon became an expert in the library-like mu-

whenever staff need to know the history of a piece within the Museum, whether for exhibits, publications, or public programs.

Currently working at the Museum at least one day a week, Martha continues to catalog database entries and assist in special projects with Registration staff members Jennifer White, Amy Heggemeyer, and Cheri Vitez. In the last year, she has joined the exhibit committee for the

VOLUNTEER EXTRAORDINAIRE: MARTHA LANDIS

by Robin Fossum

*Martha examines
a 14th-century
parchment and seal.*



Vrooman, and later had they had two daughters, Julia and Martha. Professor Landis taught at Illinois from 1925 to 1961. During those years, the Landis family traveled abroad many times, visiting Germany, Italy, Austria, France, Spain, England, and Denmark. Martha graduated from University High School, received an LAS undergraduate degree from Illinois, then earned her MS in library and information science. After working at Cornell for five years, she came back to Urbana as a librarian in the Reference Library at the University.

Though Martha does not consider herself a "joiner," in the 1990s she became involved with the Natural History Museum and was soon asked

seum jobs of data entry and artifact cataloging. Her first big project was entering into databases information about packing artifacts during the move of the collections from Lincoln Hall to the new Spurlock location. She spent three days a week recording new entries by artifact number, then re-checking them for accuracy. Following the several-year move, Martha then used her library skills to reorganize the Spurlock Library, now housed in the Board Room in the Museum's office area. She has also worked alongside other volunteers on a variety of projects in the Registration Section and for the Board. Her vast knowledge of the artifact and archival catalogs comes in handy

upcoming 100th anniversary of the Museum, working in the University archives to track down documentation of the early history of exhibits and artifacts on campus. Martha is also a member of the University Presidents Council and the Metropolitan Opera Guild. We are so glad to have a wonderful behind-the-scenes volunteer and friend like Martha!

An Introduction to Museum GARDENS

by Allan C. Campbell



Some of the better-kept secrets of the Spurlock Museum in plain sight are the four gardens. It is easy to pass them by without appreciating their significance. In this brief introduction, we hope to provide you with some background information that will inspire a closer look next time you're in the neighborhood.

In the transition from the World Heritage Museum on the fourth floor of Lincoln Hall on the Quad to our new location, the opportunity arose to create an outdoor aspect of the Museum. Four areas adjacent to the Museum were planned, each with a different cultural character and purpose. The four areas, identified on the map, are:

- 1. Prairie Grass Terrace Garden**
- 2. French Geometric Knot Garden**
- 3. Japanese Rock and Sand Garden**
- 4. Native American Medicinal Garden**

These gardens were established before the opening of the Museum in 2002 and have been evolving over the

years. In addition to University Facility and Services staff, the Spurlock Museum Guild has played a key role in maintaining the gardens. Helen Burch and Jane Myers have provided leadership and sweat equity in this effort, along with many other volunteers. A photo in our winter 2009 newsletter documents the efforts of Robin Fossum, Inga Giles, Walt Myers, Dominic Skaperdas, and Monika Vanko. Hours have also been given by Astrid Dussinger, Judy Hummel, and Vivian Larson. More volunteers are always welcome! A much-appreciated endowment for the gardens was provided by Dr. John Heiligenstein of Indianapolis, an active trustee of the Museum, and is marked by a plaque in the Native American Medicinal Garden. Another memorial in honor of the support of the former World Heritage Museum Guild sits in the Prairie Grass Terrace.

The major effort on the gardens in 2009 was a revision of the Native

the Spurlock

The Native American Medicinal Garden on the west side of the Museum.

American Medicinal Garden under the guidance of William C. Handel of the Illinois Natural History Survey, who has special interest and expertise in the topic. That garden was subdivided into woodland shade and prairie sections. Plants such as goldenseal, ginseng, wild onion, and sarsaparilla are included in the shade area. The prairie section will include yarrow, big bluestem, prairie milkweed, wild indigo, coneflowers, evening primrose, mountain mint, and spiderwort.

An expanded and much more detailed article on the gardens is planned for a future publication, complete with photographs of the results of all the recent renovations. Details about specific plants and their uses will be included. We encourage you to take a moment before entering the Museum to enjoy the gardens—and provide us with your comments, suggestions, and green thumb!

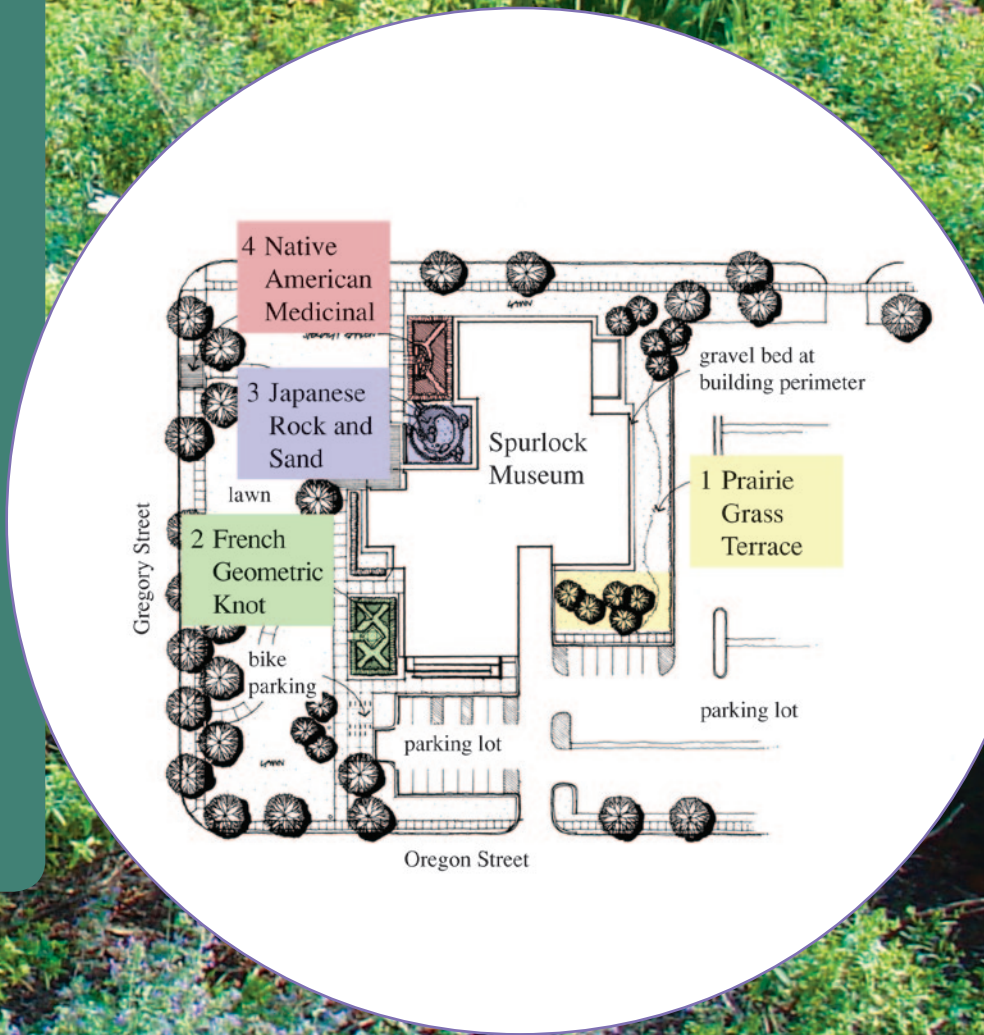

SPURLOCK MUSEUM Events

FALL

CAMPBELL GALLERY EXHIBITS

CAMPBELL GALLERY EXHIBITS

The Spurlock Museum's changing exhibits are made possible through a gift from Allan C. and Marlene S. Campbell and supported in part by the Illinois Arts Council, a state agency.

September 1, 2009–January 31, 2010

The Transforming Arts of Papua New Guinea

Papua New Guinea, a Pacific Island nation-state, is home to a remarkable diversity of grand artistic traditions. This exhibition, featuring artifacts from the Museum's own collections, explores the arts of several regions, and illustrates over half a century of change in design, media, and audience. Of special significance is discussion of artistic developments sparked by the country's independence in 1975. Visitors to the exhibit are introduced to the artistic traditions of Papua New Guinea and the ways that familiar emblems of community distinction are used and transformed to present provocative aesthetic commentary on the cultural, political, and economic struggles of an emerging nation.

For more information on this exhibit, see the article "An Inside Look: The Creation of the Campbell Gallery Exhibit *The Transforming Arts of Papua New Guinea* at the Spurlock Museum" on page 8.

March 2–July 11, 2010

Korean Funerary Figures: Companions for the Journey to the Other World

Organized by the Korea Society, New York City
Death is a given of the human condition that touches everyone in every age. In almost all cultures, the trauma of death is countered by artistic expressions of great richness. In Korea during the 19th and early 20th centuries, artisans carved wooden figures—called *kkoktu*—that were used to decorate the funeral bier. This exhibition features a collection of over 70 *kkoktu* that offer rare insights into characteristically Korean attitudes towards death. The figures of acrobats, clowns, and whimsical mystical animals included among *kkoktu* expresses a joyfulness that may seem incompatible with mourning, but the inclusion of such figures actually reflects a sophisticated appreciation of the fleeting nature of all experience. The use of *kkoktu* in funeral rites also expresses a deeply held wish that the transition to the other world will occur in an atmosphere of joyful celebration supported by many helpers.—from the exhibition text

For more information on this exhibit, see the article "Spring Exhibit Preview: *Korean Funerary Figures: Companions to the Journey to the Other World*" on page 10.

SPECIAL EVENTS

Friday, September 25, 2009, 7:00-8:30 p.m.

Opening Celebration: The Transforming Arts of Papua New Guinea

Join the Museum staff for gallery explorations, refreshments, and an introductory gallery talk by exhibit curator Professor Janet Keller. Admission is free.

Monday, October 19, 2009, 7:00 p.m.

Campbell Family Lecture: An Evening with Dr. Michael Mel

Dr. Michael Mel is the senior lecturer and head of Expressive Arts and Religious Education, University of Goroka, Papua New Guinea. He is the leading spokesperson for the PNG arts today and the recipient of the prestigious international Prince Claus Award. This prize is awarded for achievements that bring together culture and development. For this event, Dr. Mel will speak on the contemporary arts in Papua New Guinea and present a short performance piece.

Friday, October 30, 2009, 6 p.m.

Annual Spurlock Museum Guild Auction: Guided with Platinum

The Spurlock Museum Guild, formed in 1989, is committed to the Museum's educational role in the community by sponsoring cultural events, endowing the Educational Resource Center, the prairie terrace garden, and educational school programs, donating artifacts, and serving as volunteers. Proceeds of the Guild's annual auction support these efforts.

Auction items include antiques, jewelry, fine art, culinary delights, wine events, and travel opportunities. This year, the auction will feature LAS Dean Ruth Watkins and Mr. Robert Young as Honorary Hosts.

Auction festivities will take place at the I-Hotel and Conference Center, 1900 S. First St., Champaign. Tickets are available at \$60 per person, as a sponsor at \$100 per person, and as a patron at \$250 per person.

6:00 p.m. auction preview

6:30 p.m. buffet dinner

7:30 p.m. live auction

For more information, contact Pola Triandis at (217) 344-6722.

Saturday, October 31, 2009

Two ghost story concerts on Halloween will feature local favorite tellers Dan Keding, Kathe Brinkmann, and Kim Sheahan, as well as tellers from the U of I Graduate School of Library and Information Science. All donations and admission fees will support the Museum's educational programs and the Center for Children's Books.

2009 AND SPRING 2010

Gruesome, Gory, and Ghastly Ghosts and Ghouls

This afternoon family event will feature multicultural ghost stories told in the Museum's galleries. The stories will be appropriate for children grades K-8. The children will receive bags of candy to start their trick-or-treating off right. Suggested donation: \$5
2:00-3:30 p.m.

So You Think You've Heard Ghost Stories...

This is the ghost story concert for the strong of heart. It is for adults only (age 16 and above). We're not kidding. Refreshments during the intermission will help ensure that everyone gets their Halloween candy allotment. Admission: \$5
7:30 p.m.

Wednesday, November 11, 2009, 7:00 p.m.

Spurlock Museum Guild Lecture and Performance Series: What's Yours is Mine: Contemporary Art, Appropriation, and Traditional Copyright

Dr. Jacquelyn Lewis-Harris is the director of the Center for Human Origin and Cultural Diversity at the University of Missouri-St. Louis and presently holds the title of assistant professor in both anthropology and the College of Education. She lived and worked extensively in the Pacific for 27 years with an emphasis on Papua New Guinea and the Pacific Islands diaspora. She currently consults for several national and international museums as an independent curator. Her talk addresses the difficulties that arise when contemporary Papua New Guinean artists appropriate traditional Papua New Guinean art designs and forms from a non-related cultural group. In a global era when images circulate worldwide on the Web or in commercial products, this issue of local copyrights is critical for everyone.

Saturday, February 6, 2010, 2:00-3:30 p.m.

Winter Tales

Join us for one of the Museum's most popular annual events, a concert of American Indian tales, told during the winter months, the traditional time of telling. Each year, a first voice teller is featured in an educational and entertaining performance for listeners of all ages. Past tellers have represented Northern Cheyenne, Lakota, Cherokee, Kiowa Apache, Mohawk, Choctaw, and Ojibwa tribes. Winter Tales concerts are sponsored by an endowment from Reginald and Gladys Laubin. Admission: \$5

Saturday, February 20, 2010, noon-4:00 p.m.

Heirlooms, Artifacts, and Family Treasures: A Preservation Emporium

Organized by the Preservation Working Group of the University of Illinois, this informational event welcomes visitors to meet and talk with preservation specialists whose expertise ranges from antiquities to modern digital media. Have you ever wondered how to preserve that old film of family memories or take care of grandma's quilt? Bring your small, hand-held items to the

Museum or come with images of larger items and have your preservation questions answered by the presenting experts. For further information contact Jennifer Teper at (217) 244-5689.

Saturday, April 10, 2010, 12:30-4:00 p.m.

Spurlock Museum WorldFest 2010

Last year's spring festival broke all attendance records, and this year promises to be just as popular, celebrating the wondrous variety of performance arts practiced around the world and offering hands-on activities for everyone. Recommended donation: \$5

AsiaLENS: AEMS Documentary Film and Discussion Series at the Spurlock 2009-2010

This series of public film screenings and lecture/discussion programs is organized by the Asian Educational Media Service (AEMS) at the Center for East Asian and Pacific Studies. It is planned in collaboration with the Spurlock Museum and presented in the Knight Auditorium. Films to be shown will include *Betrayal*, the Oscar-nominated story of a Laotian refugee family, and *Daughters of Wisdom*, which looks at the work of Tibetan nuns. Guest scholars and members of the campus and local communities will introduce the films and lead post-screening audience discussions. The dates are November 3, December 1, February 2, March 2, April 6, and June 15.

Check the Museum's calendar of events for individual film confirmations and www.aems.uiuc.edu for descriptions and trailers.

All public performance events are sponsored in part by a grant from the Illinois Arts Council, a state agency. For more information on all exhibits, programs, and events, please visit the Museum's website (www.spurlock.illinois.edu), the online Calendar of Events, and future printed publications.



FRIENDS

OF THE SPURLOCK MUSEUM

The Spurlock Museum thanks the many individuals and companies for their generous support.

Mr. Anthony R. Ackerman
Mr. and Mrs. Scott A. Aikman
The Allan C. and Marlene S. Campbell Foundation
Alumni Holidays, Inc.
Charlene K. Anchor
Mrs. Margaret Faletti Anderson
Andrae's Harley-Davidson, Inc.
Mr. and Mrs. Joseph Antonello Jr.
Mr. M. J. Archer
R. Allen Avner, Elaine S. Avner
Mrs. Shirley T. Axel
Bacaro
Mr. and Mrs. Stanley B. Balbach
Bank Champaign NA
Dr. and Mrs. Donald G. Bartlett
Mrs. Carolyn M. Baxley
Mr. and Mrs. Wayne E. Bekiares
Mr. Ronald J. Benes
Mr. and Mrs. L. Jerome Benson
Mr. Harlan J. Berk
Mrs. Dorothy Berkey-White
Ms. Maureen H. Berry
Mrs. Andra L. Bez
Mrs. Pauline Birky-Kreutzer
Mr. and Mrs. Henry B. Blackwell II
Mrs. Mary A. Blair
Dr. Barbara E. Bohan
Mrs. Marie R. Bohl
Ms. Barbara Bohor-Denny
Boltini Lounge
Mrs. Camille J. Born
The Bread Company

Dr. and Mrs. Gerald D. Brighton
The Brown Bag
Ms. Helen C. Burch
Busey Bank
Ms. Marina Buttitta
Calico Jewelry
Dr. and Mrs. Allan C. Campbell
Prof. Andreas C. Cangellaris
Mr. Jerry A. Carden Mr. Timothy W. Temple
Mr. Robert H. Chappell Jr.
Ms. Athan Y. Chilton
Cinema Gallery
Ms. Joan M. Clement
Dr. Huguette Cohen
Coldwater Creek
Prof. and Mrs. J. Ronayne Cowan
Cracker Barrel
Ms. Barbara J. Craig
Mr. and Mrs. Earl R. Creutzburg
Mrs. Betsey Cronan
Crouse Printing & Mailing
Dr. Shirley Springer Crouse, Mr. David D. Crouse
Prof. Clark E. Cunningham, Dr. Aulikki Kokko-Cunningham
Dr. David Y. Curtin, Dr. Constance O'Hara Curtin
Dr. James H. Davis, Prof. Elisabeth B. Davis
Dr. Raymond L. Den Adel
Mrs. Loretta K. Dessen
Dr. Carol I. Diener, Prof. Edward F. Diener

Mrs. Oscar H. Dodson
Dom's Patio Villa
Mr. Joe W. Donohue
Robin C. Douglas
Monsignor Edward J. Duncan
Mr. John G. Dunkelberger II
Mrs. Astrid Dussinger
Eastern Rug Gallery
Prof. and Mrs. James Economy
Ms. Murle Edwards
El Toro
Embassy Tavern and Grille
Ms. Kristi Emilsson
Mr. and Mrs. Robert D. Espeseth
Esquire Lounge, Inc.
Euro Mart, Inc.
Mrs. Elizabeth M. Felts
Miss Gloria J. Fenner
Fidelity Charitable Gift Fund
Fiesta Cafe
Firefly Jewels
Ms. Mary E. Fisher
Ralph T. Fisher, Ruth M. Fisher
Mrs. Karen P. Flesher
Mr. and Mrs. William D. Forsyth Jr.
Prof. and Mrs. Robert M. Fossum
Framer's Market
Mrs. Margaret A. Frampton
Mrs. Renate Franciscono
Mr. and Mrs. George V. Freeman
Mr. Fred A. Freund
Fuad's Creative Hair Design
Mrs. Mary M. Gaddy

Ms. Judy M. Gamble
Garnets & Glass
Mrs. Rita J. Gentry
Prof. and Mrs. Eugene Giles
The Great American Seafood Company
Prof. Georgia M. Green
Ms. Jane E. Green
Griggs Street Potters
Mr. and Mrs. Francis Hacker Jr.
Dr. Mary Elizabeth Hamstrom
Harlan J. Berk, Ltd.
Ms. Kathleen T. Harleman
Heartland Gallery
Mr. Morris L. Hecker Jr.
John H. Heiligenstein, MD
Mr. Pedro J. Heller
Hickory River Smokehouse
Ms. Sara B. Hiser
Dr. and Mrs. John H. Houseworth
Dr. John W. Hummel, Ms. Judith C. Hummel
Charles M. Hundley, Barbara S. Hundley
Dr. and Mrs. James C. Hunt
Mrs. Ingrid Hutchings
International Galleries
The Iron Post
Prof. and Mrs. E. Atlee Jackson
Siti Mariah Jackson
Prof. Howard Jacobson, Dr. Elaine Z. Jacobson
Prof. and Mrs. Eric Jakobsson
Jill Bush Contemporary Jewelry
Dr. and Mrs. Robert W. Johannsen
Mrs. Katherine M. Johnston
Ms. Hye-Seung Kang
Kennedy's at Stone Creek, Inc.
Mrs. Jill P. Knappenberger
Betty Ann Knight
Dr. and Mrs. Napoleon B. Knight
Ko Fusion
Ms. Shelly Kotecki
Mr. and Mrs. Charles Evan Kozoll
Dr. Dale V. Kramer
Prof. and Mrs. Wayne R. LaFave
Ms. Martha Landis
Dr. Carl S. Larson
Reginald Laubin Estate (DEC)
MAJ Stephen A. Lawrence, Mrs. Ye Suk Lawrence

Le Peep Restaurant
 Dr. Sara de Mundo Lo
 Ms. Ruth E. Lorbe
 Mike N Molly's
 Dr. and Mrs. Walter J. Maguire
 Mrs. Verica Marcovich
 Mr. Howard R. Martin
 Mr. and Mrs. Fernand L. Marty
 Mr. Allan Matthews
 Mrs. Joanne J. McIntyre
 Dr. and Mrs. Donald J. McKenna
 Ms. Michelle McKinney
 Mrs. Donna Knudson McPherson
 Mrs. Anna J. Merritt
 Mr. Geoffrey A. Merritt
 Mr. and Mrs. John J. Micetich
 Dr. Antonios Michalos
 Mr. Conrad Bogdan Miczko
 Mrs. Elizabeth B. Miley
 Ms. Jill M. Miller
 Milo's Restaurant
 Mr. Joe Minneci
 Minneci's Ristorante
 Mr. and Mrs. Phillip C. Morgan
 Mrs. Yoko Muroga
 Dr. Walter L. Myers,
 Ms. Jane L. Myers
 Natural Gourmet
 Mr. Iver M. Nelson Jr.
 Prof. and Mrs. Bruno Netti
 Mr. and Mrs. Frederick C.
 Newport
 Prof. and Mrs. E. Eugene Oliver
 Dr. Richard W. Oram,
 Ms. Conna E. J. Oram
 Prof. and Mrs. Howard Osborn
 Mr. Robert E. Osiek
 Ms. Gerrie A. Parr
 Ms. Kelly A. Paulini
 Mrs. Barbara J. Peckham
 Pekara Bakery & Bistro
 Mrs. Aiko K. Perry
 Dr. and Mrs. Tom L. Phillips
 Ms. Chew Chin Phua
 Prairie Fire Glass
 Mr. Ronald W. Prescott
 Mrs. Wendy L. Preston
 Proctor Hospital Lab Employees
 Prof. and Mrs. John E. Prussing
 Mrs. Faye B. Puckett
 Mr. and Mrs. Richard D. Pummell

Mr. and Mrs. Richard M. Pyatt
 Mrs. Adlon Jorgensen Rector
 Regent Ballroom Inc.
 Dr. Selma K. Richardson
 Ring of Fire Glass Art
 Mr. and Mrs. Kyle Robeson
 Mrs. Elizabeth P. Rogers
 Mr. and Mrs. Arnold H. Rudnick
 Mr. and Mrs. Clarence A.
 Schlueter
 Mr. Chris Schmidt,
 Ms. Julia Schmidt
 Mr. Michael Schwegmann
 Dr. Grover L. Seitzinger
 Seven Saints Restaurant & Bar
 Ms. Merrily Shaw
 Ms. Kim E. Sheahan
 Dr. and Mrs. Charles R.
 Shepardson
 Mrs. Mary G. Shobe
 Prof. James B. Sinclair
 Mr. Melvyn A. Skvarla
 Ms. Elizabeth A. Smith
 Mr. Charles A. Smyth,
 Ms. Audrey L. Ishii

Mr. Jon D. Sokolski,
 Ms. M. S. Dodds
 Mrs. Hermia G. Soo
 Mrs. Joan Sozen
 Spa Envy & Spa
 Dr. Paul S. Spalding
 Spritz Jewelers
 Prof. Margaret S. Steffensen
 Mr. and Mrs. Allan L. Steinberg
 Ms. Susan C. Stone
 Stonehill's Books
 Stotler Charitable Trust
 Ms. Edith A. Stotler
 Mr. Burton E. Swanson
 Ms. Joan K. Sweeney
 Mrs. Harlean Swing
 That's Rentertainment, Inc.
 Prof. and Mrs. John Thompson
 Prof. and Mrs. Robert L.
 Thompson
 Mr. and Mrs. Raymond M.
 Timpone Jr.
 Timpone's Restaurant
 Mrs. Ina Tomaras
 Marie Griffith Tompkins

Dr. Deborah Townsend
 Prof. and Mrs. H. C. Triandis
 Triple T Car Wash and Lube, Inc.
 Mr. and Mrs. Allan M. Tuchman
 Upsie Daisy Florist
 Mr. James E. Vermette
 Mr. and Mrs. Bill Volk
 Mr. John H. Walter Mrs. Joy
 Crane Thornton-Walter
 Dr. Yu Ian Wang
 Mr. and Mrs. William D. Watson
 Mr. and Mrs. Wayne G. Weber
 Mr. Everett V. Westmeyer,
 Ms. Katharina A. Westmeyer
 Prof. and Mrs. Norman E.
 Whitten Jr.
 Ms. Cynthia Williams
 Dr. Charles L. Wisseman III,
 Dr. Sarah U. Wisseman
 Mr. and Mrs. H. Ross Workman
 Dr. and Mrs. Rollin G. Wright
 Mr. and Mrs. Mark Yarbrough
 Mr. and Mrs. David L. Zell
 Dr. and Mrs. R. T. Zuidema

FRIENDS OF THE SPURLOCK MUSEUM

Your support is very important as we work to meet the needs of the public through programs and exhibits in the new Spurlock Museum. Memberships run from July 1 through June 30. Thank you for your continued support.

To become a Friend, mail your tax deductible gift check, along with this form, payable to University of Illinois Foundation, Harker Hall, MC-386, 1305 W. Green St., Urbana, IL 61801

YES! I am pleased to support the Spurlock Museum with my gift of:

\$1,000 \$500 \$250 \$100 \$50 Other \$ _____

My check is enclosed (payable to UIF/Spurlock)

I wish to make my gift of \$ _____ by credit card:

Visa MasterCard American Express Discover

Credit Card # _____ 3 or 4 digit CID # _____ Exp. Date _____

Credit card billing address _____

Signature _____ Print name as it appears on the card _____

My gift will be matched. Company Name _____

Name: _____

Address: _____

City: _____ State _____ Zip _____

Home Phone: (_____) _____ Email: _____

Make your gift online!

Visit the College of LAS website at www.las.illinois.edu/giving

Your gift is tax deductible as allowed by law.

Please return this card with your gift. **THANK YOU.**

SPURLOCK MUSEUM

University of Illinois at Urbana-Champaign
600 South Gregory Street
Urbana, IL 61801

Nonprofit Org.
U.S. Postage
PAID
Permit #75
Champaign, IL



Diablada costume and mask. Oruro, Bolivia.
Spurlock Museum acquisitions from 2007 and 2009.